

How Electronics Changed Impedance Measurements (Corrected 5/04)

Henry P. Hall

Senior Staff Scientist GenRad, Inc., retired
35 River Street, Concord, MA, USA 01742 Email: hphall@aol.com

Abstract - *This is a history of commercial instruments that measure impedance from the 1930s to the present day. It concentrates on general-purpose and production-test bridges and meters that measure resistance, capacitance and inductance at low frequencies. It intends to show how electronics has changed these electrical measurements just as it changed all other technologies.*

I. INTRODUCTION

The history of early electrical measurements is well documented by Keithley [1] but his story ends at 1940. The last edition of Hague, the "bible of bridges", revised by Foord [2], has a short section on history and discusses over 150 bridge circuits. It was published in 1971 and has a chapter on "active" bridges. Oliver & Cage [3], also published in 1971, has a brief mention of automatic bridges as well. Apparently the more recent history of low-frequency impedance measurements is told only in separate papers and company publications. This paper attempts to tell the story of these measurements from the manual bridges of the 1930s to those instruments in use today. It is the story of how electronics, vacuum tubes, transistors, operational amplifiers, integrated circuits, microprocessors and computers, changed the way we make these measurements. It will concentrate on commercial, general-purpose instruments that measure resistance, capacitance and inductance (R, C and L) at 1 kHz and other low frequencies.

The reader may note that many of the instruments mentioned below are those that were made by the General Radio Co. [4], (later GenRad, also known as just "GR") which suggests bias on the part of your author who worked there for over forty years. This may well be, but this company did make many innovations in impedance measurements, as they did in many other fields, and their products were better documented in their monthly journal, the *Experimenter*, than were those of most other companies.

II. THE "UNIVERSAL" OR "RLC" BRIDGE

The first instrument to measure R, L and C was the GR Type 650-A Impedance Bridge [5] designed by R. F. Field and introduced in 1933. Before that there were separate instruments to measure the different quantities. The 650-A used the same bridge components switched to form four different bridge circuits: dc R (Wheatstone), and ac series C (deSauty), series (Maxwell) and parallel (Hay) inductance. It also read D of capacitors and Q of inductors directly at 1 kHz. It was battery operated (four large No. 6 dry cells) and was self-contained except for headphones that were used as

the ac detector. The ac source was an electromechanical vibrator or "hummer" tuned to 1 kHz. The dc detector was a galvanometer. Note that the term "bridge" now meant an instrument for measuring impedance as well as a specific type of circuit, but the term was limited to instruments and circuits that use a balance or "null" method.

This instrument was very popular and was considered so important that during World War II the US government urged GR to have it assembled at a second site, away from the East Coast. The company selected to do that was Brown Engineering (later Brown Electro-Measurement) in Oregon. They not only made it, they improved it with what became known as the "Brown Bridge" [6]. Later they made a new bridge designed by F. Brown and D. Strain, the BECO Model 250 [7] (1952) and the company eventually became Electro Scientific Instruments, ESI, which became GR's main competitor.

Vacuum-tubes oscillators had been used as signal sources with ac bridges ever since they were first invented. Likewise vacuum tube amplifiers were used as bridge detectors. Perhaps the first to combine them in an instrument was the combination of the 650-A bridge and the 650-P1 Oscillator and Detector designed by Lamson [8] and introduced in 1946. The -P1 unit fitted in the battery compartment of the 650-A. It used "Twin-T" selective RC networks both in the oscillator and the tuned amplifier, but still used external headphones following the amplifier. The power required by the vacuum tubes necessitated the use of line power.

Over thirty other companies made what were often called "universal" or "LCR" (or RLC, CRL etc) bridges. They all used the same bridge circuits, but many used different readout devices; dials, pointers, decades, concentric decades (as in the ESI 250) and linear "slide rule" adjustments.

GR finally replaced the venerable old 650-A in 1957 with the 1650-A [9]. This was one of the first instruments to use transistors. It used one in the oscillator and three in the tuned ac detector, one of these to drive the indicating meter thus retiring the headphones. The lower power requirements of the transistors allowed it to be powered by four D cells that, with its smaller size and unique case, made it easily portable. The accuracy of the 1650-A, like the 650-A, was only 1%, limited by the ability to read the main dial. The ESI 250 with its higher resolution decade adjustment had substantially better accuracy (0.1% for R, 0.2% for C and 0.3% for L). In 1960 ESI introduced their 291-A [10] measuring system with even better, 0.05%, accuracy. This forced GR to come up finally with a new readout scheme for its Type 1608-A [11] (1962), which allowed 0.05% accuracy also. These were probably the two most accurate RLC bridges ever made.

III. THE NEED FOR SPEED

After the World War II, the electronics industry grew rapidly and, as a result, so did the number of passive electronic components produced. In testing these parts, “throughput” was vital, but it took time to balance a bridge. An alternative was to use an impedance meter, an ohmmeter for dc resistance and an ac meter for C or L. The latter were similar to ohmmeters but used an oscillator as an ac source and an ac detector. The source voltage was held constant, or adjusted, so that the meter could read directly in the desired parameter. Examples were the Boonton Electronics (BEC) Model 71 Capacitance Meter [12], the Radiometer Type MM2 RLC Meter and a Ballantine Laboratories model 320 Direct Capacitance Meter [13]. However, the accuracy of these instruments was not sufficient for production testing of many components being limited by the ability to read the analog meter, and moreover, most of them read only the value of a capacitor or inductor and gave no measure of D or Q.

Some instruments that did read phase were the early (1947) Z-Angle meter by Technology Instruments (T.I.C.) [14] (designed by L. Packard) and the type GB11 Impedance Meter by Radiometer [15], [16] (1960), but both of which required a bridge-like balance for magnitude so that a meter could indicate phase using the residual unbalance voltage. One meter that did read magnitude and phase was the later (1965) Boonton Radio (later Hewlett-Packard) Vector Impedance Meter [17].

One solution to the speed-vs-precision problem was to use a bridge unbalance voltage to read the difference between the DUT and a standard of similar type and value on an analog meter. If this difference were small, it did not need to be measured accurately to get high overall precision. This idea was used for dc in “resistance limit bridges”, the first being the GR 1652-A [18]. These usually included a decade resistor as an adjustable standard that would be set to the nominal value so that the meter would read percent deviation. The decade could also be used to make a conventional bridge balance. For ac, there were “impedance comparators” which required an external standard. The earliest of these, such as the Southwestern Instruments (S.I.E.) Model E2 (1954) and the Industrial Test Equipment Co. Type 1110 (1955), measured only the magnitude of the difference between the DUT and the standard. The GR 1605-A [19] (see figure 1) was the first (1956) to measure both magnitude and phase difference. The latter, in radians, is very nearly equal to the D difference for capacitors or inductors if D was small (or Q high) and the Q difference for resistors. This instrument used 19 vacuum tubes and that made it quite warm.

The 1605-A had dc voltage outputs proportional to the meter readings so that, with an analog trigger circuit and a component handler, it could form an automatic test system that could run by itself as long as similar components were being tested. The Bendix Corporation used this instrument in a system [20] for testing terminal-strip assemblies containing

components of various types and values all wired together. It compared the complex impedance between the many pairs of opposite terminals of the DUT against those of a “known good” assembly. The operation of this system was controlled by an IBM punched-card programmer and thus the system might be considered to be an early automatic in-circuit tester.

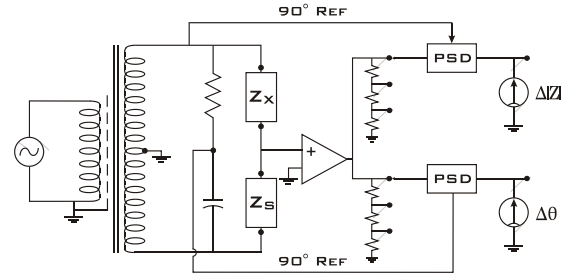

Fig. 1. GR 1605 impedance comparator: basic diagram.

IV. PRECISION ELECTRONICS, ACTIVE BRIDGES

The 1605 comparator like other impedance meters of the time used vacuum-tube amplifiers in the actual measurement circuit, but usually there was an easy method of calibrating their gain, which was apt to vary with warm-up and over time. Tubes also had many other disadvantages such as producing heat, requiring power and high voltages, limited life, being large and causing noise. The advent of reliable transistors made practical active high-feedback amplifiers whose characteristics depended almost completely on stable passive components and thus they could be used in a bridge circuit itself where the accuracy depended directly on their gain.

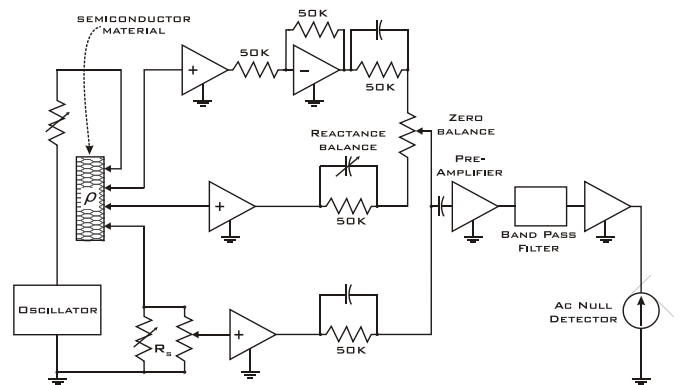

Fig. 2. Logan’s active bridge for semiconductor measurements.

However, the first known example of an “active” bridge was one designed by Logan [21] (1961) of Bell Labs (see figure 2) that did use vacuum tubes. He wanted a bridge to make low-frequency ac four-point-probe measurements on semiconductor materials that required potential probes with

extremely high input resistances. For these he used three-stage, unity-gain, feedback amplifiers with the input stages having open grids. He also used a three-stage inverting amplifier to make the required differential voltage measurement and a voltage divider-amplifier combination as the main balance adjustment. Note that the use of a low-frequency ac signal (85 and 390 Hz) avoided errors from dc-offset voltages.

The first commercial active bridge did use transistors. GR wanted to make an inductance bridge capable of passing high current through the DUT and to make the bridge direct reading in Q, as well as L, at many frequencies. Finding no suitable bridge circuit, they also used the potentiometer-amplifier combination to drive the both capacitance standard (C_s) and selected resistors (G_s) for the Q balance in their type 1633-A Incremental Inductance Bridge [22], [23] (1962), see figure 3. This circuit also included an inverting voltage-to-current converter that allowed the use of a grounded detector. It can be considered as a modification of the Maxwell inductance bridge circuit. The resistor used for the Q balance, G_s , was switched with the selected frequency so that it had the proper value to read Q directly at that frequency.

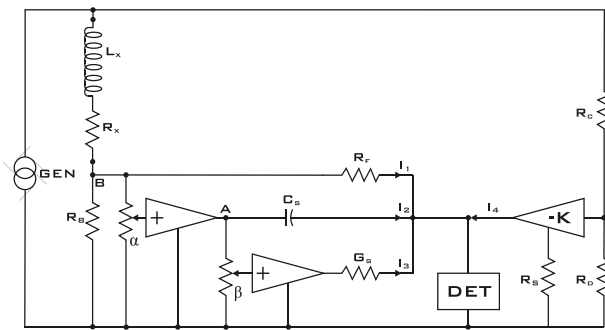

Fig. 3. The GR 1633 incremental inductance bridge circuit.

V. AUTOMATIC BRIDGES

Another way to gain measurement speed was to make a bridge balance automatically, using motors to drive the variable components. This was done as early as 1951 when Graham [24] used phase-sensitive detectors and servomotors to balance an inductance bridge. Frischman [25] used a similar system to balance a GR 716-C capacitance bridge. Commercial motor-driven bridges were made by Rhode & Schwarz (type KVZA in 1960), and the Barnes Development Co. (type 61 in 1961). Automated System Laboratories Ltd used motors to set a seven-decade transformer voltage divider in their Model A7 Automatic Precision A.C. Double Bridge for platinum resistance thermometry (1974).

There were several electronic “semi-automatic” bridges [26]. The Hewlett-Packard model 4260A [27], [28] (1966) and the Rhode and Schwarz type RCLB [29] (1969) used

biased nonlinear elements to make the secondary D-Q balance necessary for null thus making the main balance easier especially if there were a “sliding null” (poor balance convergence) problem [30]. Another manual balance was required to get the actual D or Q value. Wayne-Kerr’s “push button bridge”, Model B641 [31] (1966), was manually balanced but the operator was guided in making that balance which improved measurement speed.

A breakthrough was made in 1964 by R. Fulks who had worked on the active inductance bridge (see above). Instead of using pots as adjustments, he made the balance electronically by driving capacitance and conductance standards with current-to-voltage amplifiers fed by digitally-controlled, decade conductances. These used germanium transistors as switches in a 1-2-4-2 weighted scheme for each decimal digit. The decoded digital settings of these decades gave the direct reading result for parallel C and G. The bridge also measured D by driving the G adjustment with the output of the C adjustment. It could measure negative C from which the user could calculate parallel inductance from $L = -\omega^2 C$. This first electrically-balanced automatic bridge, the GR 1680-A [32], [33] used a transformer-ratio-arm bridge circuit to get precision ratios and good guarding (see fig. 4).

There was a problem: there was no computer available to control the bridge and not even any integrated circuits. The 1680 system used over 260 transistors that were on 24 circuit boards. Most of these were logic boards used to control the bridge and drive the digital display. To test these, GR designed a functional board tester, a device they thought others could use so we sold such systems and eventually they became GR’s main product line.

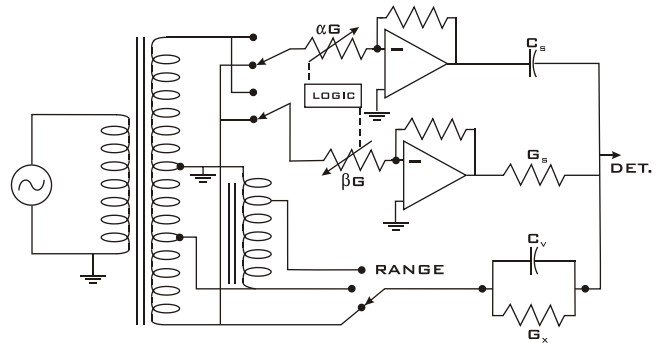

Fig. 4. The GR 1680-A automatic capacitance bridge: basic circuit.

Although this automatic bridge was rather expensive, it still was extremely popular because it was easy to use and because it was much faster. However its main advantage may have been that it was *programmable*, not just automatic. Its functional settings could be controlled by an external computer and its output read by a computer. The computer available at that time was the Digital Equipment Company’s PDP-8. Such a combination of bridge and computer found many uses and GR became one of DEC’s biggest customers.

This too changed GR's future by getting them into the systems business.

Such systems made the automatic testing of capacitors quite practical [34], and made possible measurements that would have been impractical, even impossible, before. One was the testing of 100 pair telephone cables for cross talk. A system [35] at Western Electric did this by measuring the direct capacitances between every pair, 4950 measurements. This cut their test time to 1/7 the time used by manual measurements that tested only sampled cables.

Later GR made other automatic bridges, including one that measured R, L and C, the GR 1683 [36] (1970). This required a different circuit for each parameter, so, like the old 650-A, it used the same circuit elements, now some active, switched to form different bridge circuits. It also had no computer but at least digital integrated circuits were available by then. It also used a very few linear ICs.

VI. COMPUTER-DEPENDENT BRIDGES

If there were always a computer associated with a bridge, it could measure R, L and C with just one bridge circuit. Kabele did this in the GR 2230 system [37] (1975) that had a dedicated DEC LSI-11 microcomputer in it. The bridge, by itself, measured only parallel C and G, the easiest quantities to measure, but the computer could calculate series C and R, D and Q. Like the GR 1680, it could measure negative capacitance so that inductance could be calculated, but now the computer did it, not the user, and it calculated *series* L which is usually what is wanted. The computer also controlled the bridge thus greatly simplifying the digital circuitry.

When small microprocessors were available, the Boonton Electronics Co. (BEC) made an automatic 1 MHz capacitance bridge that contained one, the BEC 67A designed by R. C. Lee [38] (1976). It used an Intel 4004 processor and the Young transformer-ratio-arm bridge circuit [39] modified by using relay-switched capacitors instead of a differential capacitor. This bridge measured only parallel C and G and calculated the equivalent series values and D. This was the first microprocessor-based impedance-measuring instrument, but it was still a true bridge circuit, albeit automatically balanced.

An interesting computer-dependent system described by Geldart [40] was the Bell Labs Computer Operated Transmission Measuring Set (COTMS), a coaxial system that made measurements from 50 Hz to 250 MHz. First one made three calibrating transmission measurements with a short circuit, an open circuit and a standard of known value connected in turn to an open port. Then when the transmission was measured with unknown impedance connected, its value could be calculated from a rather complicated formula that required a small computer. This principle (based on Bode's work [41]) is used to calibrate many modern measuring instruments.

VII. DIGITAL METERS

While GR was making automatic bridges, other companies were making quite accurate digital ac impedance meters, which, like automatic bridges, didn't require balancing, but they did cost a lot less. Because they had digital displays, their accuracy was not limited by the accuracy of an indicating meter and usually they had accuracies of about 0.25%, which was close to that of automatic bridges.

Examples of early meters were the Electro-Instruments Model CD Digital Capacitance Meter (1960) that used edge-lit Lucite® display numerals and the Micro Instruments model 5300A Capacitance Tester (1965) that used "Nixie" neon glow tubes. The later ESI Model 251 Digital Impedance Meter (1973), which measured R, L, and C, used a LED display. Although GR had looked with some distain on such meters as being inferior to their bridges, in 1973 they finally decided to make one by themselves, the GR 1685, which specified 0.1% accuracy at 1 kHz [42].

This instrument, like many others, use an inverting amplifier in the measurement or "front-end" circuit (see figure 5) to bring the junction of the DUT and standard to near zero voltage to provide good guarding (immunity from capacitance from this junction to ground) and to make the voltage E_S closely equal to the voltage across R_S . This circuit works well at low frequencies, but deteriorates at higher frequencies where the op-amp gain falls off. HP devised an integrating-modulating scheme for their 1 MHz LCR Meter (type 4271, 1974) that made a separate "bridge" balance to bring this guard point to close to ground potential even at higher frequencies, a method later used on many of their other instruments [43].

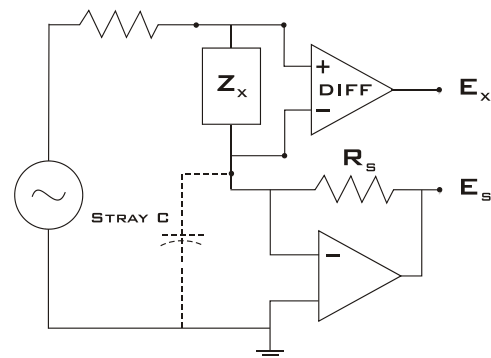

Fig. 5. "Front End" circuit used in the GR 1685 impedance meter.

These meters usually used phase-sensitive detectors to get the proper dc voltages that were then divided by a "dual-slope" or "up-down" integrator to get the desired impedance parameter [44]. Most such meters could not measure two quantities, such as C and D, at the same time (although the HP 4271 did) because that required two divisions and they usually had only one integrator and no memory to store one quantity while they measured another.

Meters had another important problem; that of generating precise phase references. To measure the equivalent series capacitance, as is usually desired, one had to generate a reference pulse that was 90° out of phase with the voltage across the standard resistor (E_S in figure 5) that carried the same current as did the unknown. Not only is it difficult to get a precise and stable 90° phase shift, but it is also difficult to get either reference, 0° or 90°, when the ac voltage used to get them becomes small as it does when measuring a small capacitance or other high impedance. Getting the proper phase references was critical to getting accurate D measurements and manufacturers of low-loss plastic capacitors were always clamoring for better D accuracy.

VIII. MICROPROCESSOR-BASED IMPEDANCE METERS

Microprocessors could do more than control an automatic bridge or convert the bridge output to get the desired measurement parameters: *they could change the way impedance measurements were made.* The basic division that defines impedance, E/I , could be made digitally, the digital division of two complex numbers. Moreover, with associated RAM, measurements could be made in sequence and stored for later calculations. This meant that a single detector and A-to-D converter could be used to measure both voltages, that across the unknown and that across the standard. Note that if a single detector is used for both measurements, its gain is not critical because both its magnitude and phase shift cancel in the division.

Moreover, with a complex division, the relative angle between the analog signals and the two phase references is not important because the division of two complex numbers depends only on the angle between them, not on their angles with respect to the references. (This is obvious using polar coordinates: $Ae^{j\theta}/Be^{j\phi} = (A/B)e^{j(\theta-\phi)}$.) This allows the use of square-wave references that are digitally generated and can easily be made exactly at 90 degrees apart. They only have to be synchronous with the signals.

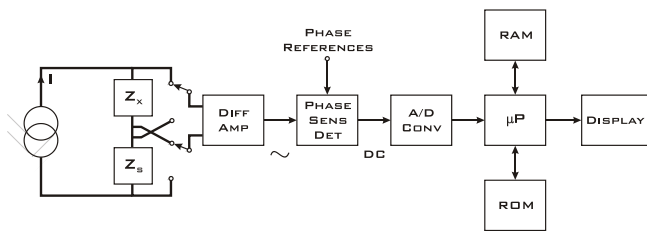

Fig. 6. Block diagram of the "Digibridge" impedance meters.

This method [45] was first used on the GR Type 1657 "Digibridge" which was introduced in 1976 [46]. This name (the result of a naming contest) is a misnomer as this instrument is not a true bridge: it is not balanced for a null.

However the term "bridge" is now often used (or misused) to refer to any impedance-measuring device. A simple block diagram of this instrument is shown in figure 6 but actually the "front-end" circuit is that of figure 5 except that a differential voltage is taken across the standard resistor as well as across the DUT. The accuracy of this instrument depends only on the accuracy of three precision resistors used as the standard, R_S , and the high-frequency clock chip used to generate the test frequencies and references. Where the GR impedance meter mentioned above had 27 adjustments, this had only one. This first Digibridge® was priced lower than the less accurate, manual GR 1650 bridge which was possible because it didn't use expensive parts or require extensive hand wiring and assembly [47].

The phase-sensitive detector in this instrument was part of the dual-slope A-to-D converter (shown in figure 7) and provides the "up" or charging slope which is not a straight line but rather a series of half sine waves resulting from the square wave sampling. This provides good filtering even though odd harmonics are passed (reduced by their number, 1/3, 1/5 etc). The "down" or measuring slope is (and must be) linear, a result of the dc current through R_b . The time taken to discharge the integrating capacitor, C , is measured by the number, N , of high-frequency pulses into a counter. Note that each value of N is completely meaningless by itself. A total of eight such measurements are made in the slowest mode, four on each signal, 90 degrees apart. The measurements at opposite phases cancel offset voltages and the current inserted to insure that the "up" slope goes up (even though actually "up" is down in 1657).

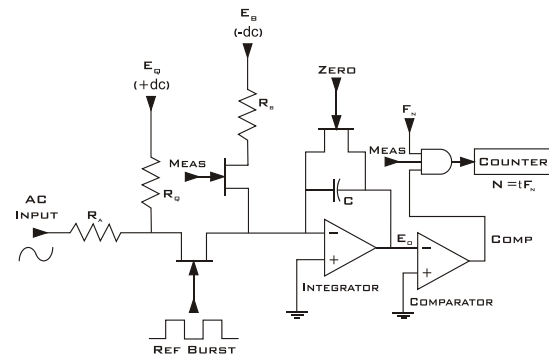

Fig. 7. Phase-sensitive detector and integrator used in the GR 1657.

This first Digibridge® made measurements of R , C , and L to 0.2% and D to $\pm .001$ at two frequencies, 120 Hz and 1 kHz. Later instruments in this line had 10 times better accuracy (at 1 kHz) and had a wide range of frequencies. More important for precision work, they had 1 ppm resolution when comparing the DUT to an entered value and close to a 2 ppm standard deviation for 1 kHz measurements taking 1 second. This is precise enough for comparing many impedance standards especially if many measurements were averaged. Several improvements were made to get this performance. First, these instruments were calibrated with a

set of four external resistance standards, one for each of its four ranges. The main limit on the accuracy specification was the stability specification of the internal and external standards provided by the manufacturer of these resistors. In practice, the actual accuracy was usually well below 50 ppm at 1 kHz over the main ranges.

Other improvements were the use of a sine-encoded multiplying D-to-A converter to sample the signals instead of the simple FET switch that gave a square wave sample. This made the detector insensitive to all harmonics (at least up to a very high ones) and improved the rejection of low-frequency noise. A very-low-loss Teflon® capacitor was used in the integrator to avoid errors caused by dielectric absorption and measurement time was saved by allowing the integrator's discharge or measuring slope to start during the sampling period if a certain threshold voltage was reached.

As well as more test frequencies over a wide range and adjustable signal levels, these later models had all the “bells and whistles” that one now expects in computer-controlled instruments such as taking the average or median of a set of measurements, multiple test limits (“bins”) for sorting components and an IEEE bus interface. They also could be much faster, up to 40 measurements per second but, of course, at much lower accuracy.

These instruments are still being produced (by QuadTech) and some consider them to be the most accurate instruments for R, L and C measurements at low frequencies. Note they still use the same microprocessor, the MOS Technology 6502 that was used in the original in 1967. At higher frequencies, the most accurate impedance meters are probably those made by Agilent (a spin-off from HP).

Many other companies—well over a dozen—made, and still make, somewhat similar instruments and some of these companies were kind enough to pay royalties to GR for use of the idea. Like the manual RLC bridges of the 1950s, these instruments come in many sizes and shapes, with various specifications, features and prices and with a variety of readout devices. The best display is that of the ESI Model 2100 Auto LCR Meter or “VideoBridge”, designed by N. Morrison (and now sold by Tegan), that uses a CRT [48]. This allows the display of the test conditions as well as the test results with their proper units. A program is available to display a histogram of the number of components that fell within the limits of various bins that was useful for quality control.

These digital meters have eventual limits on accuracy and precision. The former is mainly limited by the stability of the standards used. Perhaps the factor that limits precision the most is the count resolution of the detector. If, for example, each separate measurement (of the eight for a full measurement) takes 0.1s and the clock frequency is 40 MHz, the resolution is 0.25 ppm for a full-scale count, but most of the measurements will have a much poorer resolution. Other limitations are the linearity of the amplifiers and the detector, and various kinds of noise: cross talk between channels, coupling to synchronous pulses and just plain random noise.

Suggestions for improved precision would be the use of a more advanced A-to-D (such as a multi-stage Sigma-Delta converter), better isolation of the detector circuitry, and the use of two detectors, each measuring both channels for best accuracy but used separately for speed. More stable standards, both internal and in the calibration kit, would make tighter accuracy specifications possible.

IX. A BRIDGE FOR SUPER PRECISION

A bridge circuit that uses no active elements can give higher precision because it uses only stable, linear components. Manually adjusted, transformer-ratio-arm capacitance bridges with six and more digits have been available for some time [49]. To get the best possible precision in an automatic instrument, Andeen-Hagerling returned to the bridge principle, but used modern parts and many novel techniques [50]. Their Model 2500A Precision Capacitance Bridge has over seven-digit resolution, and a sensitivity of C to 0.5aF and of D to 1.5×10^{-8} . Moreover, it has extreme accuracy, 5 ppm, as a result of internal, precision, “quartz” capacitance standards that are in a temperature-controlled oven as well as its precise transformer ratio arms. This is far better accuracy than older manual bridges, making it the “world’s most accurate capacitance bridge” as it is advertised.

The first two decades use capacitors switched by relays between decimal taps on the precision transformer. The last five digits switch resistors instead and sum them (weighted) with an operational amplifier that feeds a third capacitance standard, a method similar to that used in the old GR 1680 (see figure 4). Thus this bridge does actually use an active device in the measurement circuit, but only to get the lesser digits.

This bridge uses a lot of relays. One way to avoid so many relays would be to combine a bridge with a meter by balancing the first few digits and measuring the remaining bridge unbalance with an A-to-D converter. The scale factor of the A-to-D would be critical, but can be made unimportant by making a second measurement using a second transformer tap, preferably an adjacent one. From these two measurements of the unbalance, the value of the DUT can be determined independent of scale factor of the A-to-D [51].

X. THE END OF THIS HISTORY?

Very few, if any, new impedance meters have been made in the last few years and apparently the A-H bridge and its two newer companions are the only new commercial bridges. Sales of such instruments have been decreasing for many years and many of the old companies who made them are gone or have sold their instrument lines. One reason for this is that fewer precision passive components are used today because analog signals are now generated, filtered and detected by digital means. Present instruments seem to be adequate for current measurement tasks so there doesn't seem

to be a necessity to mother further invention. However, there is usually a market for any instrument that is faster, cheaper and more accurate than those currently available so this should not be the end of this story.

REFERENCES

- [1] J. F. Keithley, *The Story of Electrical and Magnetic Measurements*, IEEE Press, 1999
- [2] B. Hague and T.R. Foord, *Alternating Current Bridge Methods*, Pitman, London, 1971
- [3] B. M. Oliver and J. M. Cage, *Electronic Measurements and Instrumentation*, McGraw-Hill Book Co. New York, 1971 pp. 263-318
- [4] A. E. Thiessen, *A History of the General Radio Company*, General Radio, W. Concord, MA 1965
- [5] R. F. Field, "The Convenient Measurement of C, R, and L", *The General Radio Experimenter*, April-May 1933, pp.1-4
- [6] M. E. Lee, *A Passion for Quality*, Electro Scientific Industries, Portland, OR, 1999, pp. 11 & 15
- [7] M. E. Lee, *A Passion for Quality*, Electro Scientific Industries, Portland, OR, 1999, p. 23
- [8] H. R. Lamson, "Do You Have a Type 650 Impedance Bridge", *The General Radio Experimenter*, April 1946, pp.1-4
- [9] H. P. Hall, "A New Universal Impedance Bridge", *The General Radio Experimenter*, March 1957, pp. 1-9
- [10] M. E. Lee, *A Passion for Quality*, Electro Scientific Industries, Portland, OR, 1999, p. 40
- [11] H. P. Hall, "A Precise, General-Purpose Impedance Bridge", *The General Radio Experimenter*, March 1962, pp.3-11
- [12] B. M. Oliver and J. M. Cage, *Electronic Measurements and Instrumentation*, McGraw-Hill Book Co. New York, 1971, p. 280
- [13] H. E. Thomas and C. A. Clarke, *Handbook of Electronic Instrument and Measurement Techniques*, Prentice-Hall, Inc. Englewood Cliffs, NJ, 1967, pp. 187-188
- [14] M. E. Stout, *Basic Electrical Measurements*, Prentice-Hall, Inc., Englewood, NJ, 1950, pp. 232-235
- [15] J. O. Neilsen, "A New Z-φ Measuring Instrument", *Ingerieren, International Edition*, June 1960. See also
- [16] R. Lund, "Direct Reading Meter Gives Impedance and Phase Angle", *Electronics*, Jan. 3, 1964
- [17] G. J. Alonzo, H. H. Blackwell and H. V. Marantz "Direct Reading Fully Automatic Vector Impedance Meters," *HP Journal*, January 1967
- [18] W. H. Hague, Jr., "Versatile Limit Bridge Doubles as Laboratory Standard", *General Radio Experimenter*, January 1952, pp.1-4
- [19] M. C. Holtje and H. P. Hall "A High-Precision Impedance Comparator", *The General Radio Experimenter*, April 1956 pp.1-7
- [20] H. Painter, "Impedance Comparator Adaptable to Many Kinds of Measurements and Tests," *The General Radio Experimenter*, April 1960, pp. 3-5
- [21] M. A. Logan, "An AC Bridge for Semiconductor Resistivity Measurements Using a Four-point Probe," *Bell System Technical Journal*, vol. 40, no. 3, pp. 885-920, May 1961
- [22] H. P. Hall and R. G. Fulks, "The Use of Active Devices in Precision Bridges," *Electrical Engineering* May 1962, pp. 367-373
- [23] R. G. Fulks and H. P. Hall, "A New System for Measuring the Inductance of Iron-Core Coils," *The General Radio Experimenter*, May 1962
- [24] J. F. Graham. "Automatic A-C Bridges," *Electronics*, Vol. 30, February 1951, pp.110- 116
- [25] P. G. Frischman, "Measuring Dielectric Properties Automatically," *Electronics*, August 5, 1960, pp. 56-57
- [26] EID Staff, "Automatic and Semi-automatic Component Bridges," *Electronic Instrument Digest*, June 1968, pp105-113
- [27] K. Yoshimoto, "A New Universal Impedance Bridge with Simplified Semi-Automatic Tuning," *Hewlett-Packard Journal* Vol. 18, No. 1, August 1966, pp.2-5
- [28] L. A. Whatley, US Patent 3,315,153, "Bridge Circuit Employing Self-Balancing Controlled Means," April 18, 1967
- [29] T. Schmidt and D. Kolbe, "Automatic Precision Bridge RLCB" *News from Rohde & Schwarz*, Vol. 36, No. 9, 1969
- [30] B. Hague and T.R. Foord, *Alternating Current Bridge Methods*, Pitman, London, 1971 pp. 93-99
- [31] R. Calvert and J. Mildwater, "Self-Balancing Transformer Ratio Arm Bridges," *Electronic Engineering*, Dec 1963, pp. 782-784
- [32] R.G. Fulks, "The Automatic Capacitance Bridge", *The General Radio Experimenter*, April 1965 pp. 3-13
- [33] R. G. Fulks, US Patent 3,562,641, " Impedance Measuring Transformer Bridge with Automatic Digital Balancing Circuit", Filed Nov. 25, 1968, issued Feb. 9, 1971
- [34] H. T. McAleer and R. F. Sette, "Automatic Capacitor Testing Systems", *The General Radio Experimenter*, Nov-Dec 1966, pp. 3 -18
- [35] R. G. Fulks and J. Lamont, "An Automatic Computer-Controlled System for the Measurement of Cable Capacitance, " *IEEE Trans. I&M*, IM-17, No. 4, Dec. 1968, pp. 299-303
- [36] T. J. Coughlin, "Five-Terminal Automatic RLC Bridge," *The General Radio Experimenter*, March-June 1970
- [37] W. C. Kabele, "A Fast Microcomputer-Controlled Admittance Bridge," *IEEE Trans. I&M*, IM-25, No. 4, Dec 1976, pp. 541-544
- [38] R. C. Lee, "A Microprocessor-Controlled, Automatic, 1 MHz Capacitance Bridge", presentation given at WESCON in 1976
- [39] C. H. Young, "Measuring inter-electrode capacitances", *Bell Labs Rec*, Vol 24, pp. 433-438, Dec 1946
- [40] W. J. Geldart, "Improved Impedance Measuring Accuracy with Computer-Operated Transmission Measuring Sets," *IEEE Trans. I&M*, IM-24 No.4, Dec, 1975, pp. 327-331
- [41] H. W. Bode, *Network Analysis and Feedback Amplifier Design*, Van Nostrand, New York, 1945 p. 223
- [42] H. P. Hall, "An AC-DC Ratiometer and Its Use in a CRL Meter," *IEEE Trans..on I&M*, IM-22, No. 4 Dec 1973, pp. 387-390
- [43] K. Meada, "An Automatic, Precision 1 MHz Digital LCR Meter,," *HP Journal*, March 1974
- [44] D. F. Hoeschele, Jr., *Analog-to-Digital/Digital-to-Analog Conversion Techniques*, John Wiley & Sons Inc., New York, 1968 pp.381-384
- [45] H. P. Hall, US Patent 4,196,475, "Method of and apparatus for the measurement of impedance and other quantities with microprocessor calculating techniques," filed Sept. 2, 1976, issued Apr. 1, 1980
- [46] M. A. Gipe, H. P. Hall and R. C. Sullivan, "Microprocessor Simplifies Impedance Measurements" WESCON 1976, Session 1, paper #4
- [47] H. P. Hall, "Analog Tests: the Microprocessor Scores," *IEEE Spectrum*, Apr. 1977, pp. 36-40
- [48] "LCR bridge has built-in CRT", *Electronics*, April 24, 1980, pp. 240-241
- [49] J. F. Hersh, "Accuracy, Precision and Convenience for Capacitance Measurements." *The General Radio Experimenter*, Aug-Sept 1962, pp. 3-13
- [50] C. G Andeen and C. W. Hagerling, US Patent 4,772,844, "High Precision Capacitance Bridge," issued Sept. 20, 1988
- [51] H. P. Hall, "A Digital Impedance Comparator with High Precision," *IEEE Trans. on I&M*, Dec. 1980, pp. 337-341